

Power Magnetics Design and Measurement of Power Magnetics

Charles R. Sullivan, charles.r.sullivan@dartmouth.edu

Copyright 2011

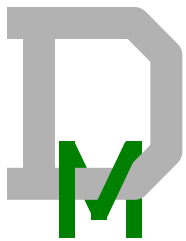

Dartmouth Magnetics and Power
Electronics Research Group



THAYER SCHOOL OF
ENGINEERING
AT DARTMOUTH

<http://power.engineering.dartmouth.edu>

High-performance high-frequency power magnetic design

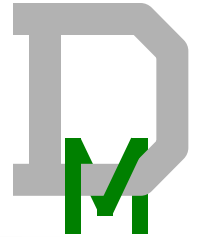

- Select winding configuration.
- Approximate analytical models for winding loss, core loss, and thermal resistance.
- Co-optimize magnetics design with circuit design:
 - Switching frequency
 - Inductance value
 - Magnetic component geometric parameters
 - Goal: efficiency vs. size tradeoff (thermal constraint)
- Fine tune design with finite-element analysis.



Select winding configuration

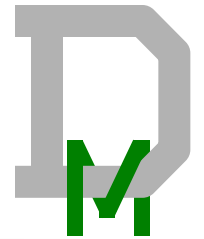

Options for low ac resistance:

- Single-layer winding
 - Can be much thicker than a skin-depth with no ac-resistance penalty.
- Multi-layer winding
 - Layer thickness is critical.
 - Typically need $d \ll \delta$, not just $d < \delta$ ($\delta =$ skin depth).

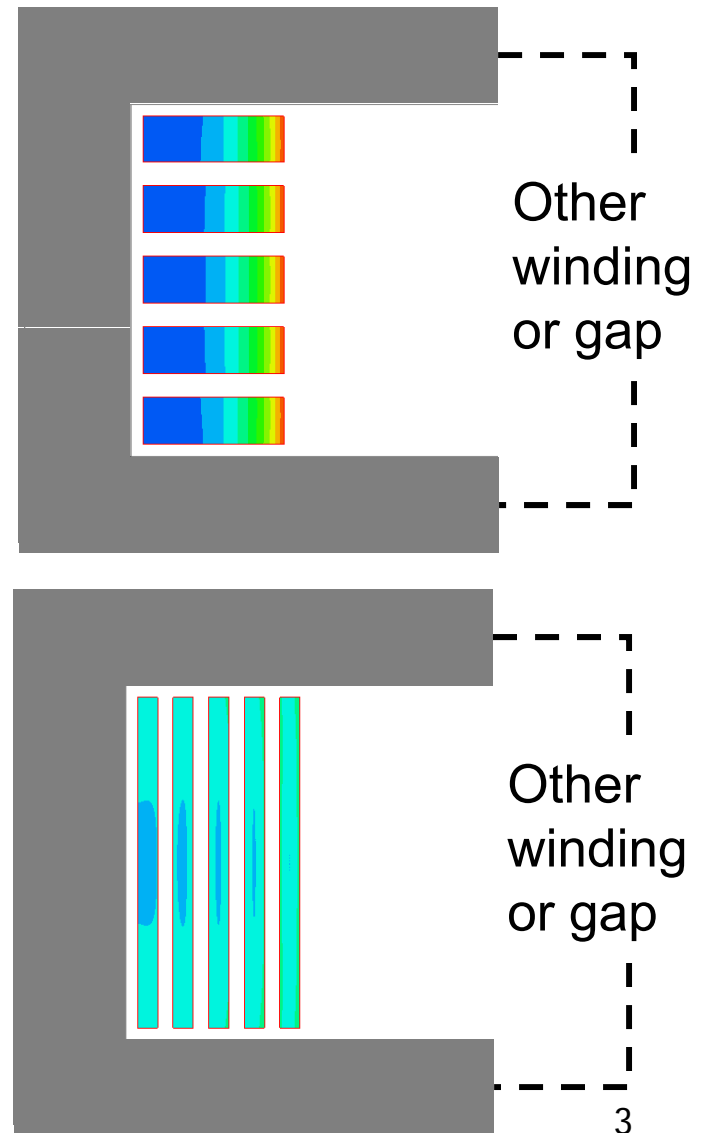

Rough Performance Estimate

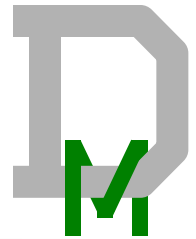

- Optimum layer thickness with p layers (Dale, 2006): $\frac{1.3\delta}{\sqrt{p}}$ (if all equal thickness)
- Improvement in ac resistance vs. single-layer winding:

$$\frac{1.013}{\sqrt{p}}$$

- For this example:
 - Theoretical 0.45
 - Actual 0.41

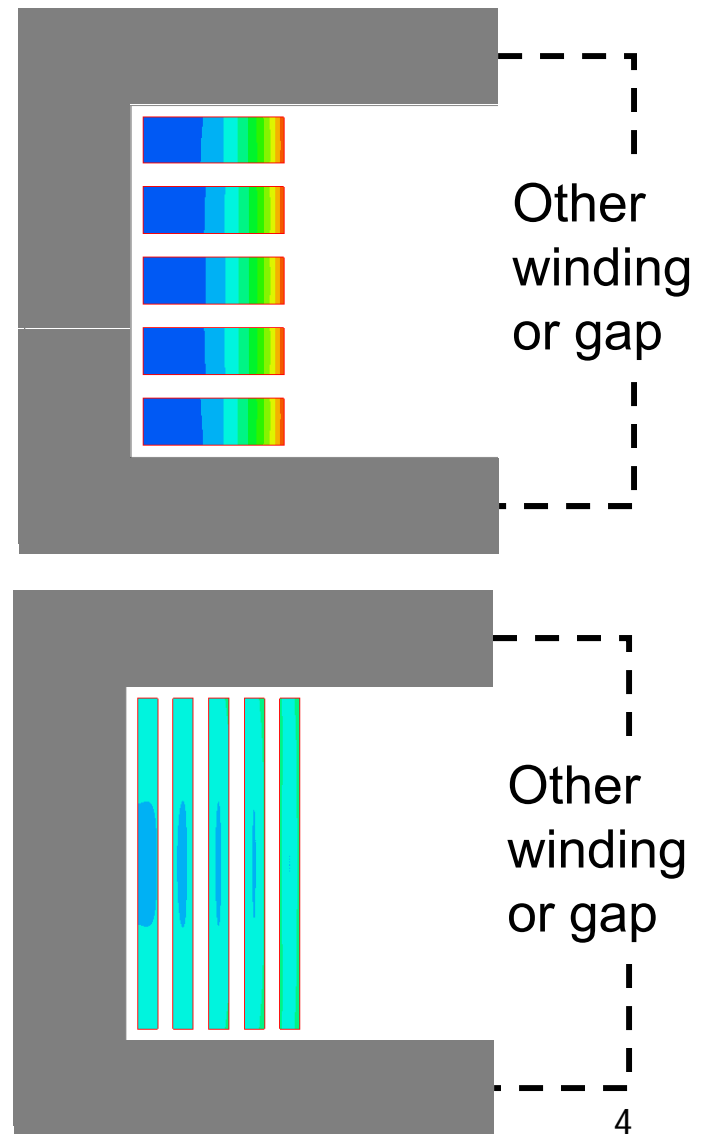

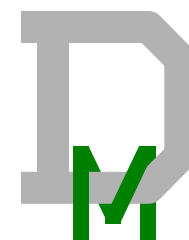

Practical winding-loss issues

- Multiple layers *in parallel* might not share current equally.
 - Twisting in litz wire
 - Interchange foil positions
- Gap effects: current likes to flow near gap.
 - Space away from gap $\geq \frac{1}{4}$ width or gap pitch (Hu, 2001).
 - Gap length has only a second-order effect on winding resistance.

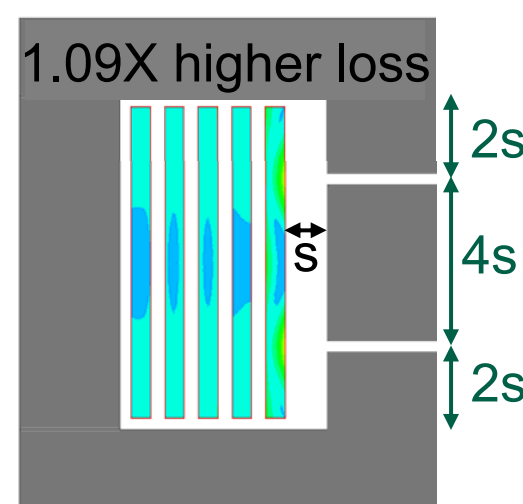
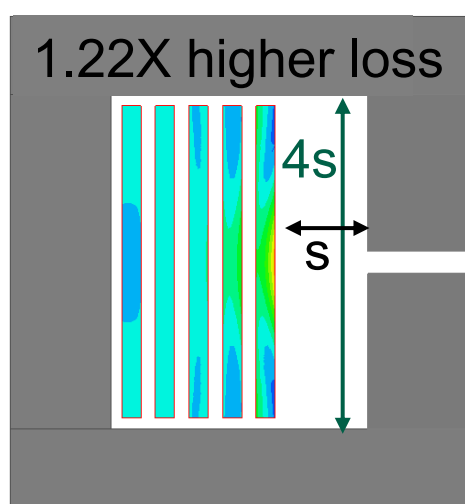
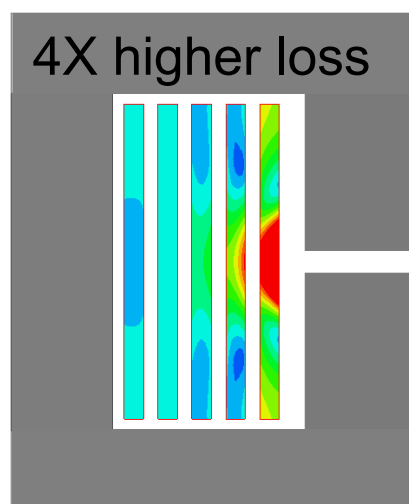
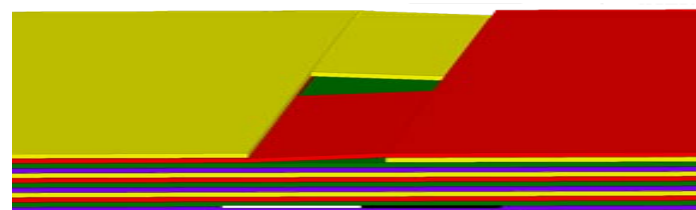

Low loss high-frequency windings: standard is litz wire

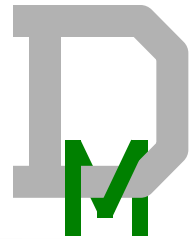

- Available improvement

$$\frac{P_{ml}}{P_{sl}} \approx 0.584 \left(\frac{d_{min}}{\delta} \right)$$

Frequency	60 Hz	20 kHz	200 kHz	1 MHz	10 MHz
Skin depth	8.5 mm	0.467 mm	0.148 mm	66 μ m	21 μ m
d = δ	AWG 0	AWG 24	AWG 35	AWG 42	AWG 51
d for 3.5X improvement	AWG 6	AWG 30	AWG 41	AWG 48	AWG 57

- Need alternatives above ~ 1 MHz

Accurate models for winding losses

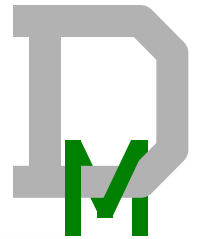

- Transformer AC resistance model: Matrix including mutual resistance terms (Spreen, 1990)

$$P = \frac{1}{2} \begin{bmatrix} i_1 & i_2 \end{bmatrix} \begin{bmatrix} R_1(f) & R_{12}(f) \\ R_{12}(f) & R_2(f) \end{bmatrix} \begin{bmatrix} i_1^* \\ i_2^* \end{bmatrix}$$

- Finding $R_{ij}(f)$ accurately over wide frequency range: (Switching-frequency harmonics require wideband model.)
 - Measurements
 - Numerical solutions
 - 1-D foil: Dowell model (e.g., Spreen, 1990)
 - Round wire, 1-, 2- or 3-D: Bessel function is not accurate for packed wire. Better: (Nan, 2004, Zimmanck, 2010).

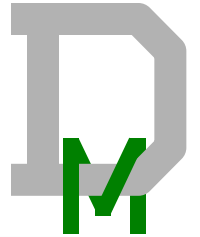

Modeling Core Loss

- Thin-film alloys and laminations:
 - Classical eddy-current
 - At high frequency, with thin dielectric, capacitance may allow additional eddy current (Yao 2009)
 - Hysteresis loss
 - Anomalous loss: model based on domain-wall motion. (Bertotti, 1998)
- Ferrites: Steinmetz curve fit to measured data....if excitation is sinusoidal.

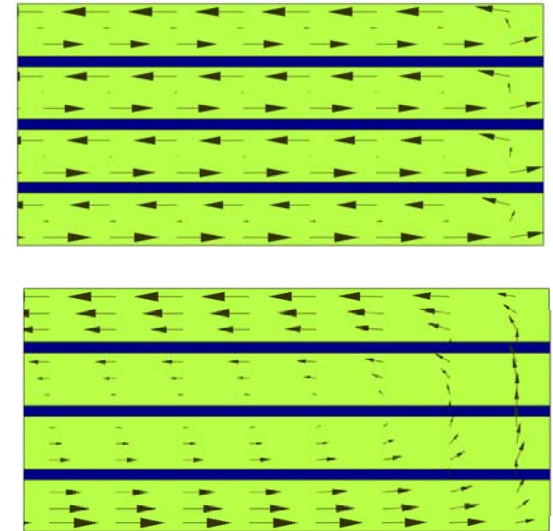

Ferrites with non-sinusoidal waveforms

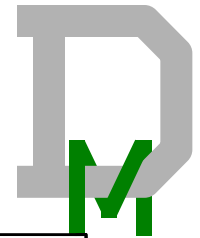

- Improved Generalized Steinmetz Equation (iGSE, Venkatachalam 2002) is more accurate than alternatives.
- Easy to use with basic piecewise linear (PWL) waveforms.
- Better alternative: measure loss with square waves and generalize to any rectangular waveform. (Sullivan 2010)
- Other effects:
 - DC bias (Mühlethaler, 2010)
 - “Relaxation” (Sullivan 2010, Mühlethaler, 2011)

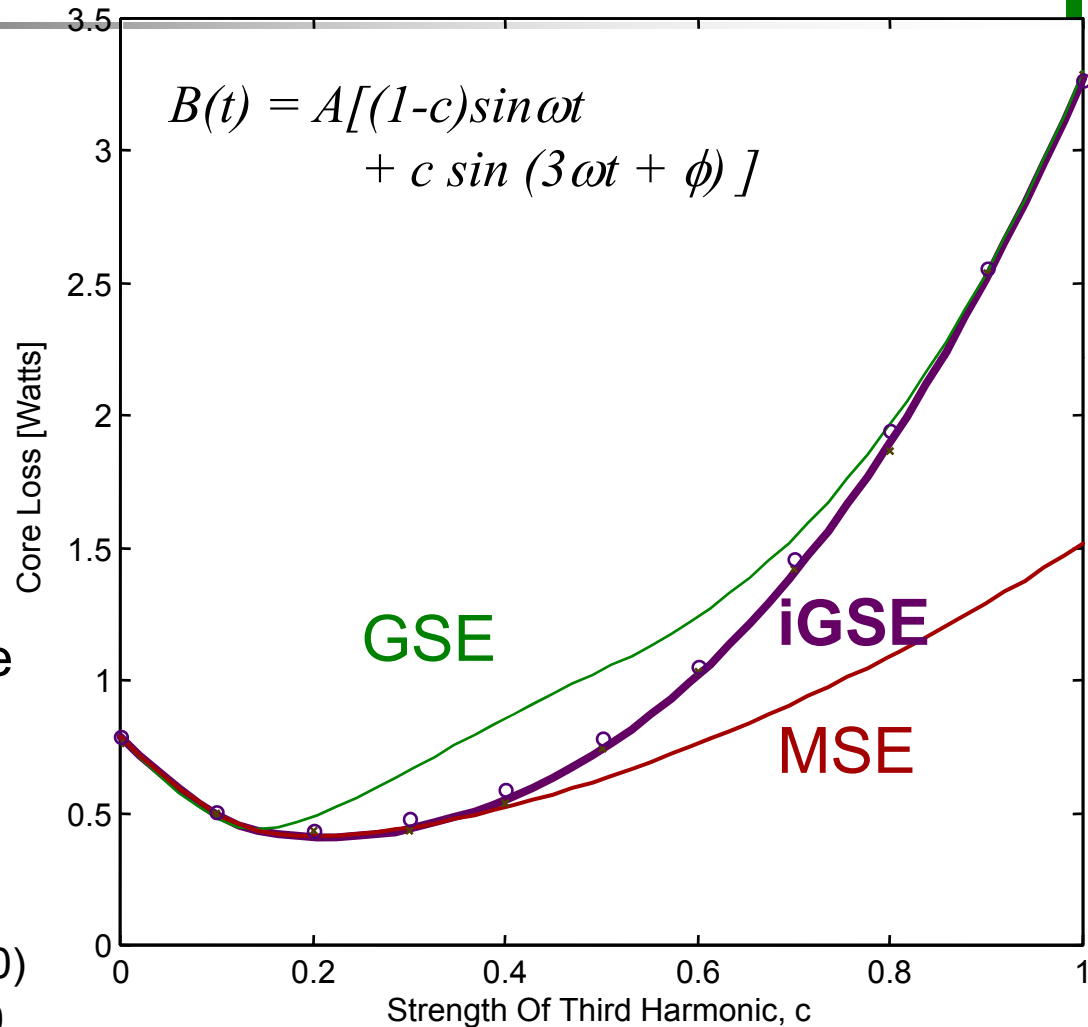



Design

- Easy way to get a mediocre inductor:
 - Large L for small ripple.
 - Can tolerate large R_{ac} with small ripple—wind for low dc resistance.
 - Saturation is more important than core loss (see Pollock, 2011 for a model)
- Path to a better inductor:
 - Optimize L and $f_{\text{switching}}$ with inductor design.
 - → Lower L , higher ripple
 - Requires low R_{ac} ... and requires circuit tricks for light-load efficiency.

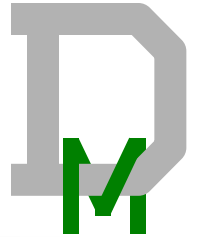

Output of optimization

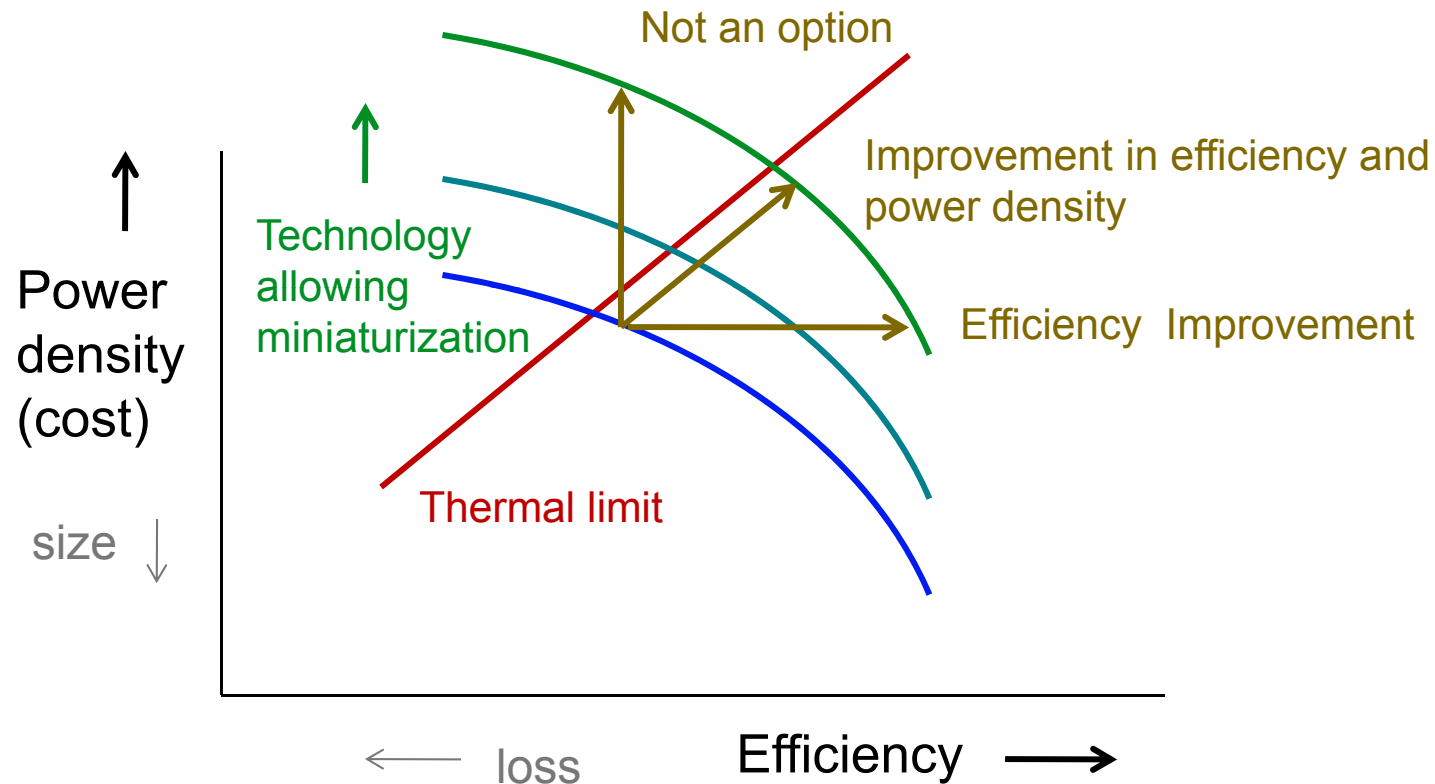

- Plot of efficiency vs. power density shows the range of attractive options.
- Progress on cost, size, or efficiency can be used to improve all of the above.

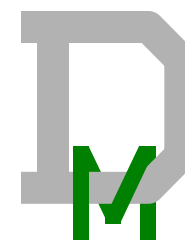

Options to consider

- Integrate multiple components (e.g. inductor, transformer) on a single core.
- Circuit designs that utilize coupled magnetic components.
- Hybrid windings for components with ac and dc or high-frequency and low-frequency current (e.g., litz wire and solid wire) (Valchev, 2005; Schaef 2012).
- Aluminum wire: enables lower loss than copper under weight or cost constraints (but not under size constraints). (Sullivan, 2008)





Existing magnetics

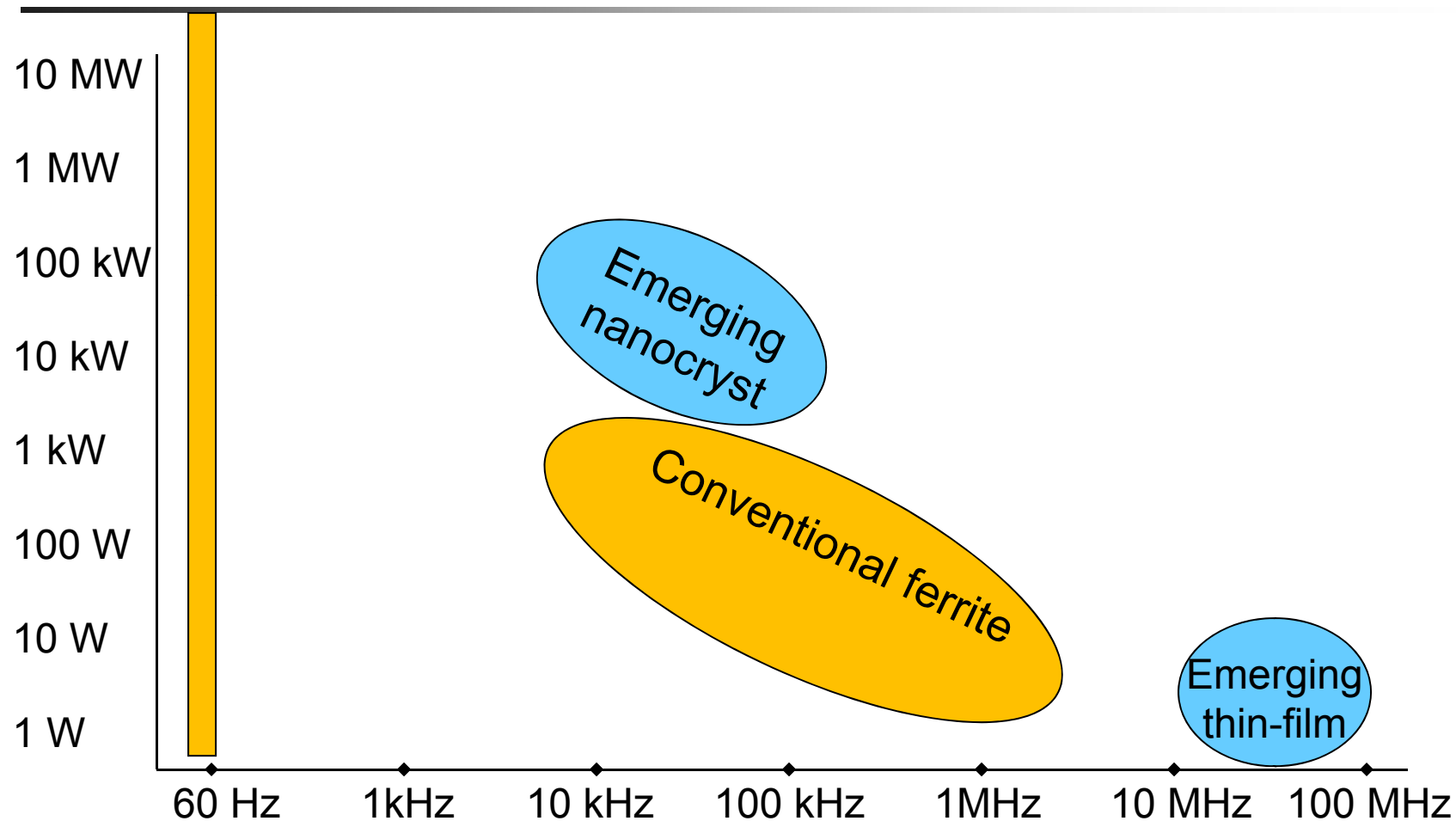

Needed with new semiconductors

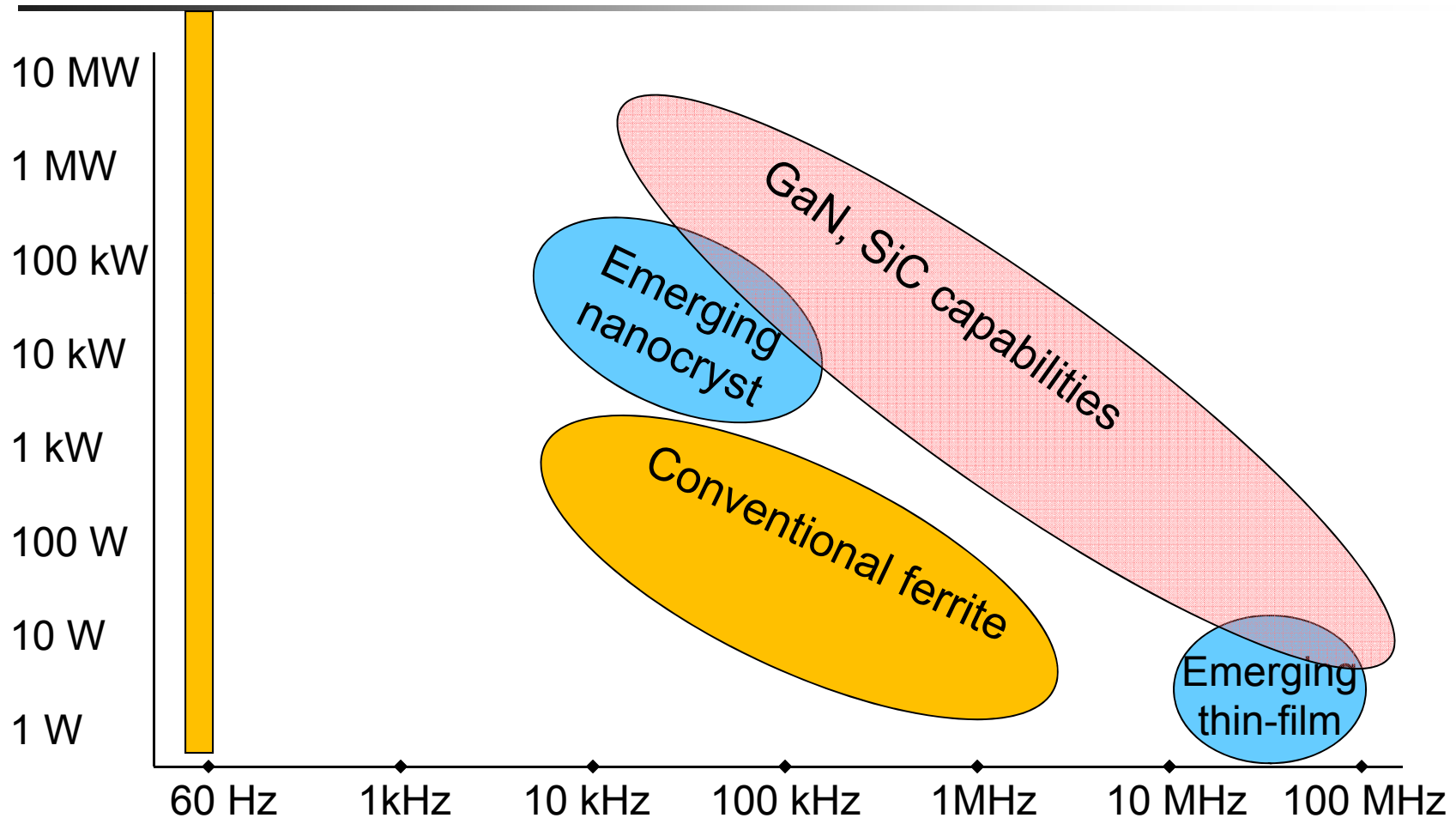
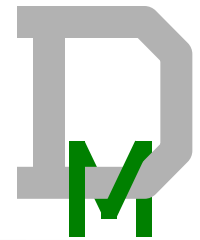

The challenge for magnetics: extending capabilities

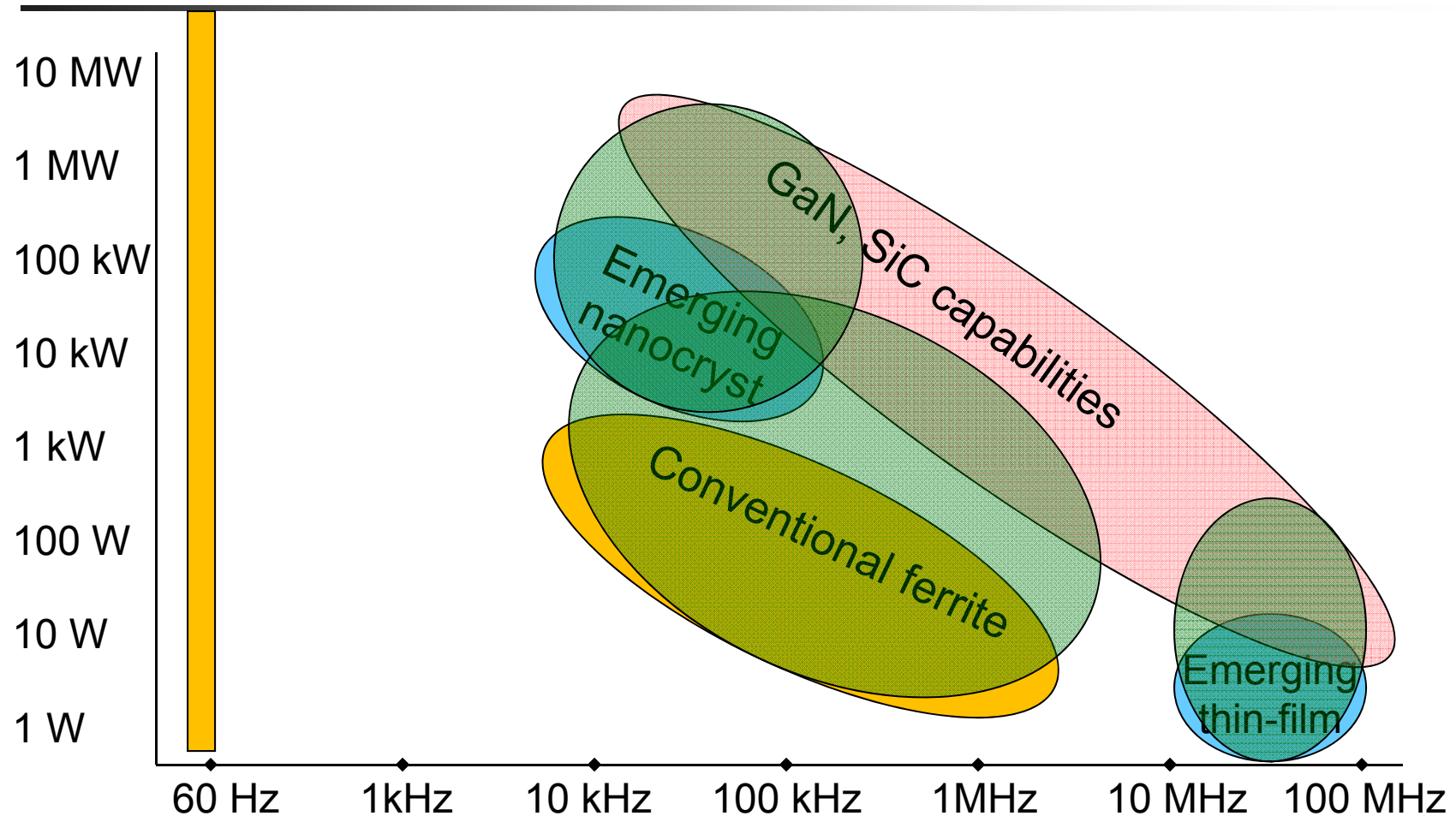
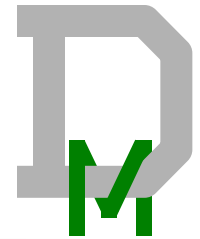

Even bigger challenges: breakthroughs needed

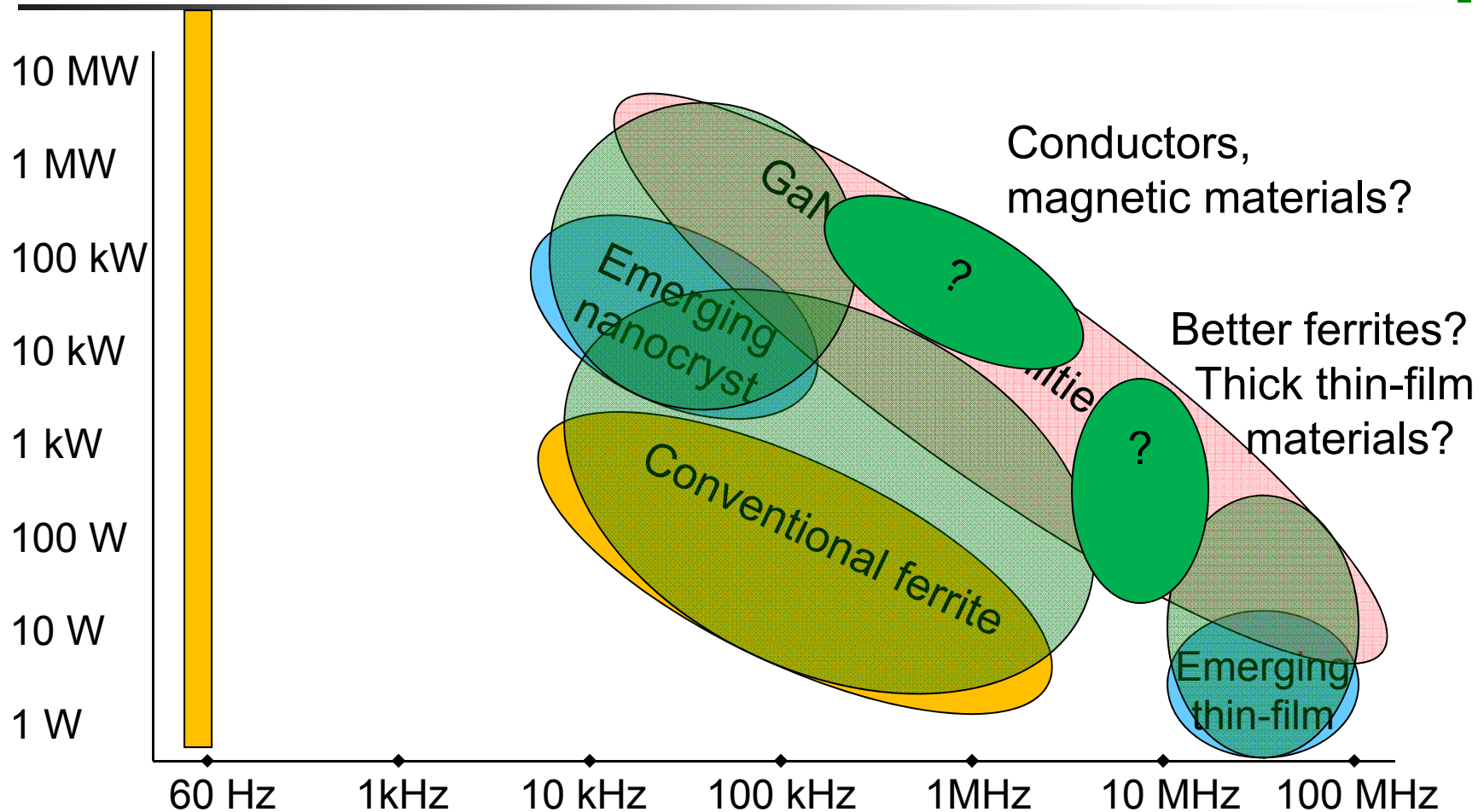

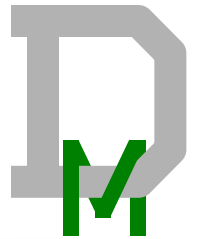

Measurement Challenges

- Accurate loss measurement of low-loss components
- Nonlinearity of core loss
- Connecting instruments with low residual impedance
- Separating core and winding losses
- Magnetic material measurement without making components



Accuracy with High Q:

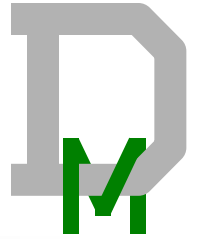

- Loss \Leftrightarrow Real(Z) (ESR)
- Good power components:
 - Real(Z) \ll $|Z|$
 - But it's still important to measure Real(Z).

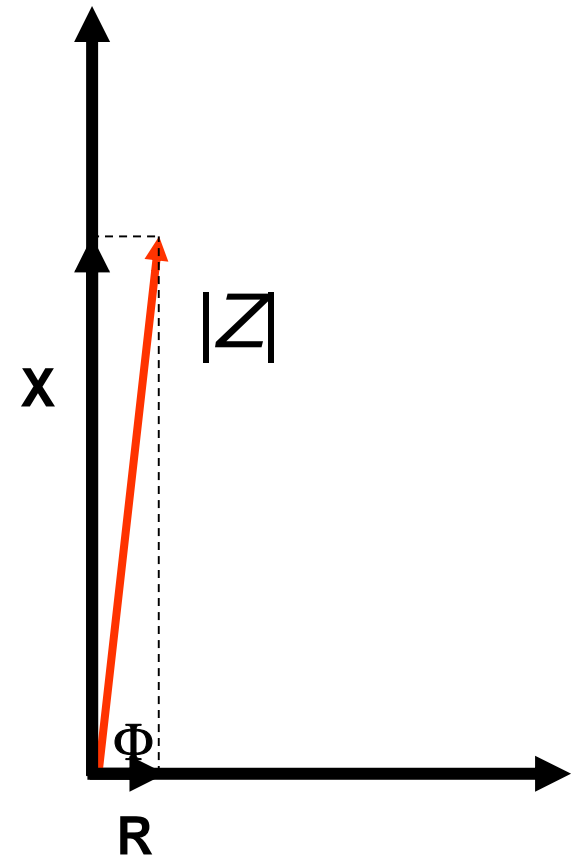

Accuracy with High Q:

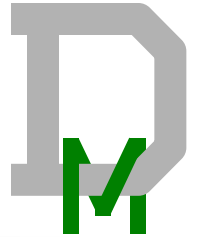

- Loss \Leftrightarrow Real(Z) (ESR)
- Good power components:
 - Real(Z) \ll $|Z|$
 - But it's still important to measure Real(Z).
- Small error in $|Z|$
 - \Rightarrow Small error in Real(Z)

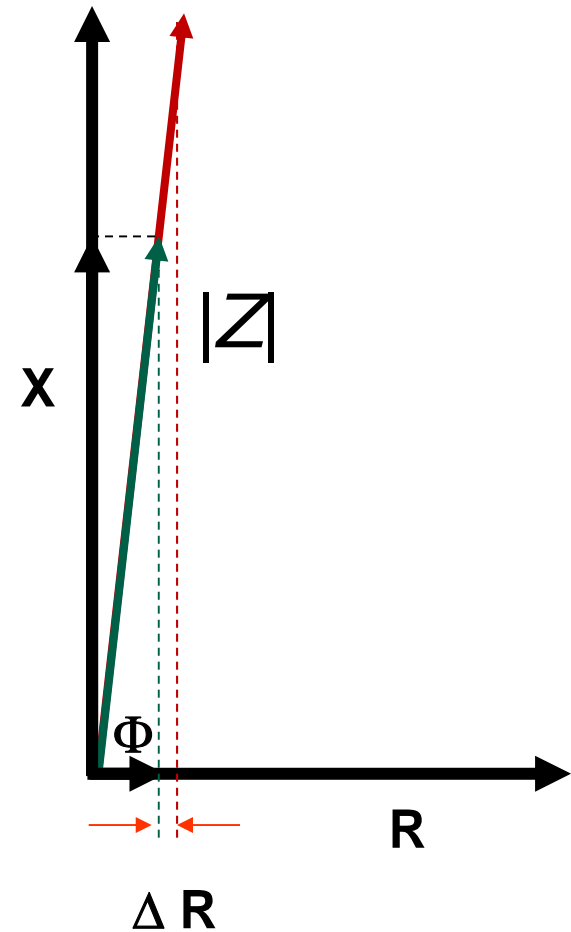

Accuracy with High Q:

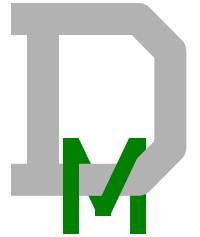

- Loss \Leftrightarrow Real(Z) (ESR)
- Good power components:
 - Real(Z) \ll $|Z|$
 - But it's still important to measure Real(Z).
- Small error in $|Z|$
 - \Rightarrow Small error in Real(Z)
- Small error in $\angle(Z)$
 - \Rightarrow Large error in Real(Z).
 - Example: $Q = 100$. $\Delta\Phi = 0.2^\circ$
 - \Rightarrow 35% error in ESR

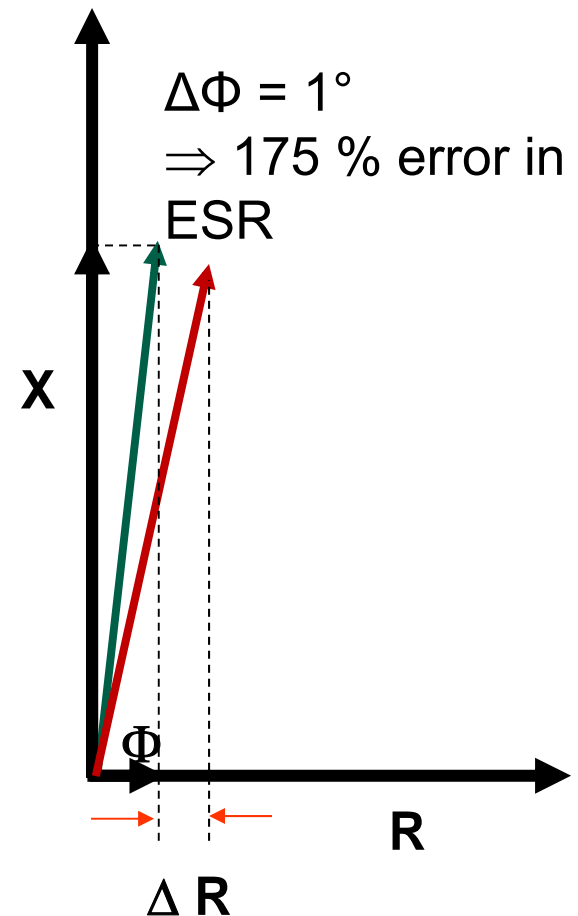

Accurate measurements with high-Q



- Use an instrument with excellent phase accuracy.
- Compensate with a low-loss capacitor to “tune out” inductance (power factor correction) (Han 2008, Mu 2010)
 - Polypropylene/porcelain/mica/air
 - May still need to measure and correct for capacitor ESR, but at least it's linear (except ferroelectrics).



Two favorite impedance instruments

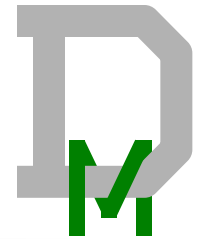

4294A

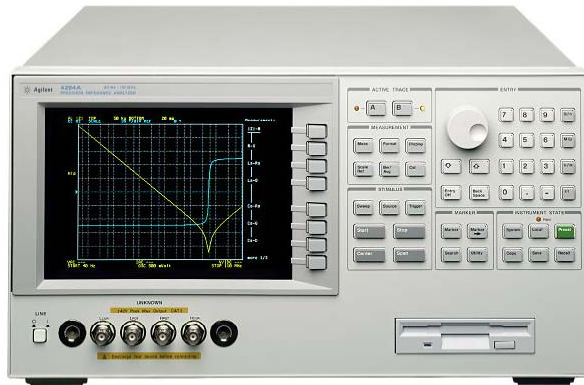

- 40 Hz to 110 MHz.
- 4-terminal pair for wide impedance range.
- Best 40 Hz to 10 MHz.
- Phase accuracy can be $\sim 3^\circ$ below 100 kHz.
(Prabhakaran, 2002)

E4991A

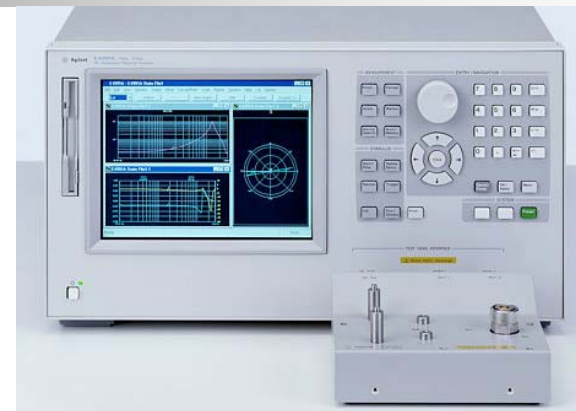

- 1MHz to 3 GHz.
- 7-mm port—best for 0.5Ω to $5 \text{ k}\Omega$.
- Best ≥ 10 MHz.
- 4-way calibration: open, short, load, and air cap for 90° phase accuracy.

4 terminal pair configuration

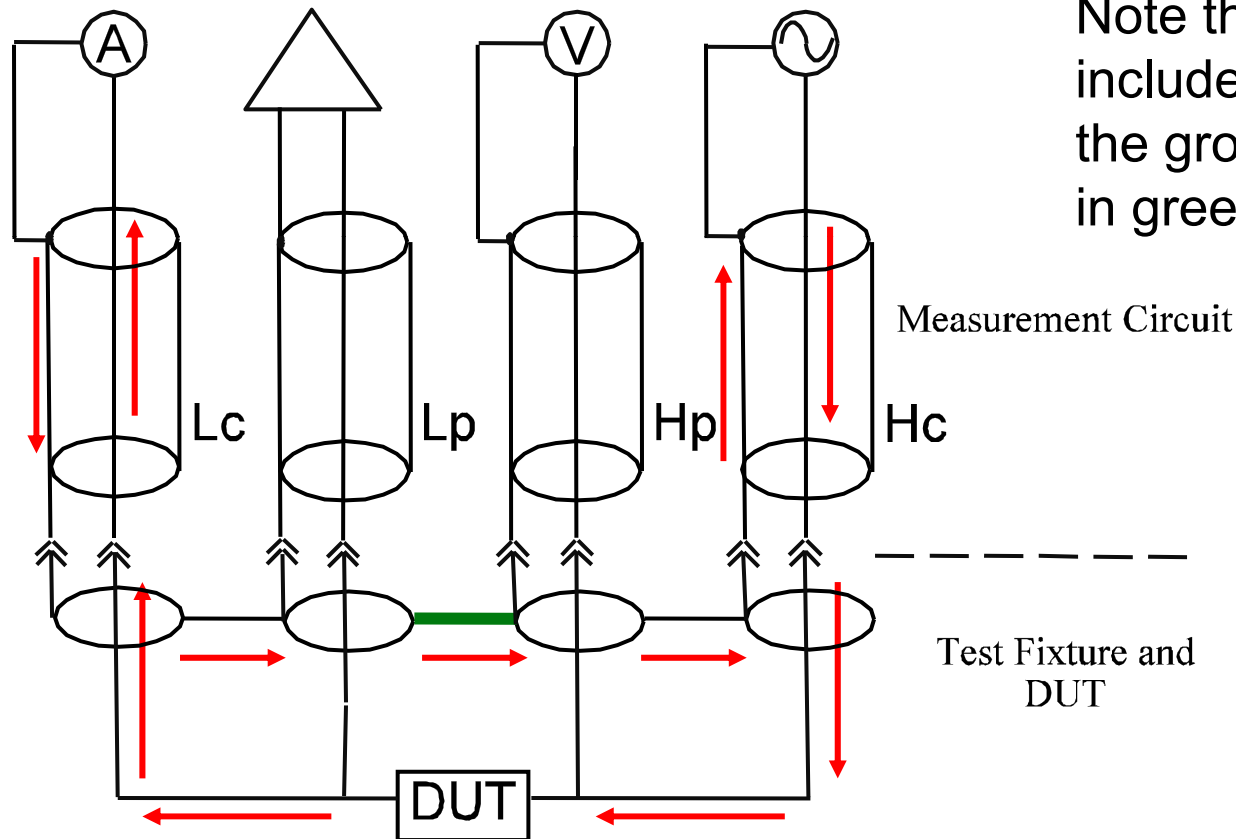
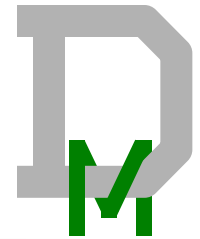

Note the measurement includes the impedance of the ground path highlighted in green.

High power measurement with a standard analyzer

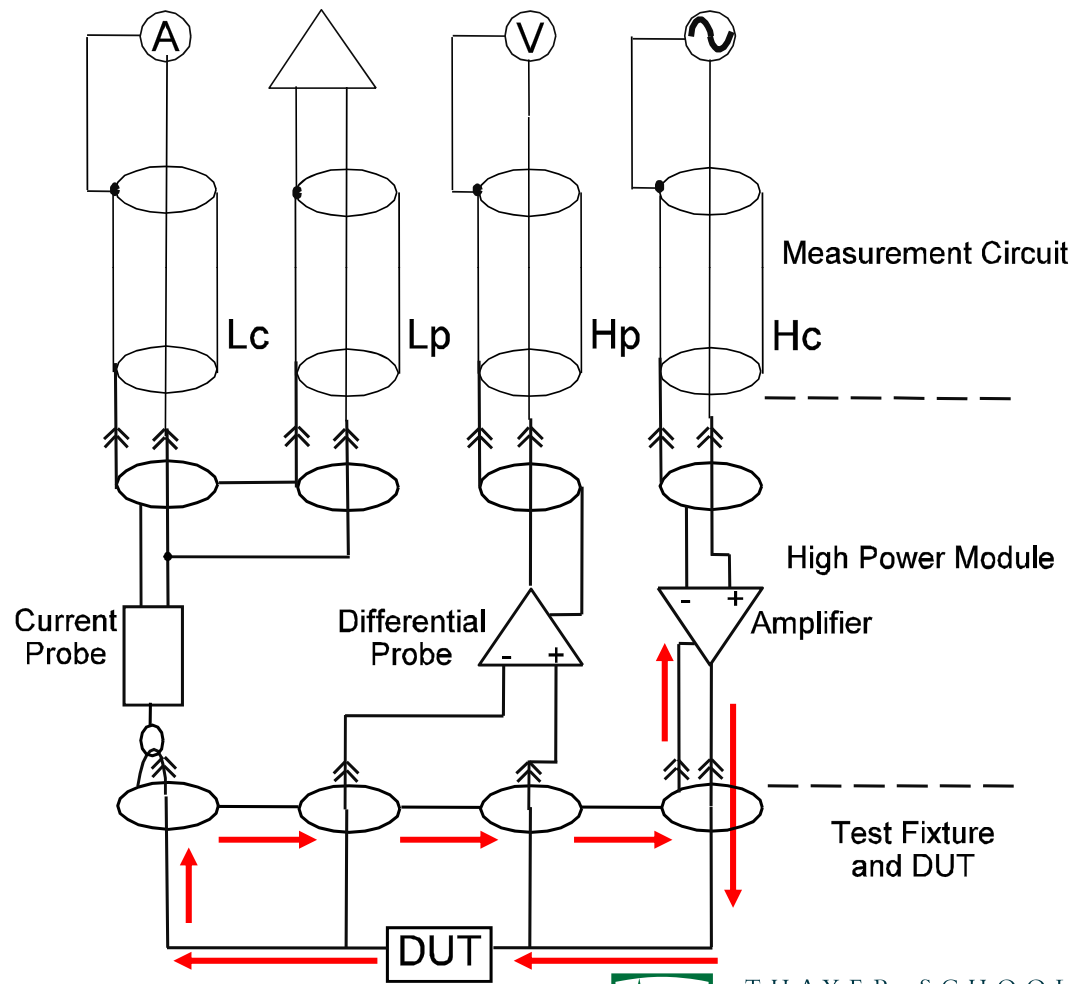

- Needed for nonlinear magnetic materials
- Demonstrated 1~300 kHz (Prabhakaran, 2002).
- Under construction: 1~30 MHz, up to 5 A drive current.



Resonant-circuit high-power testing

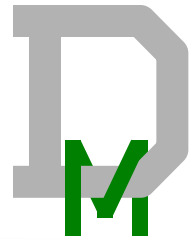

- Find Q from two amplitudes—no error from phase shift (Han, 2008).
- Resonance reduces VA requirement at input.
- Matching may still be needed for low- Z series resonant circuit.

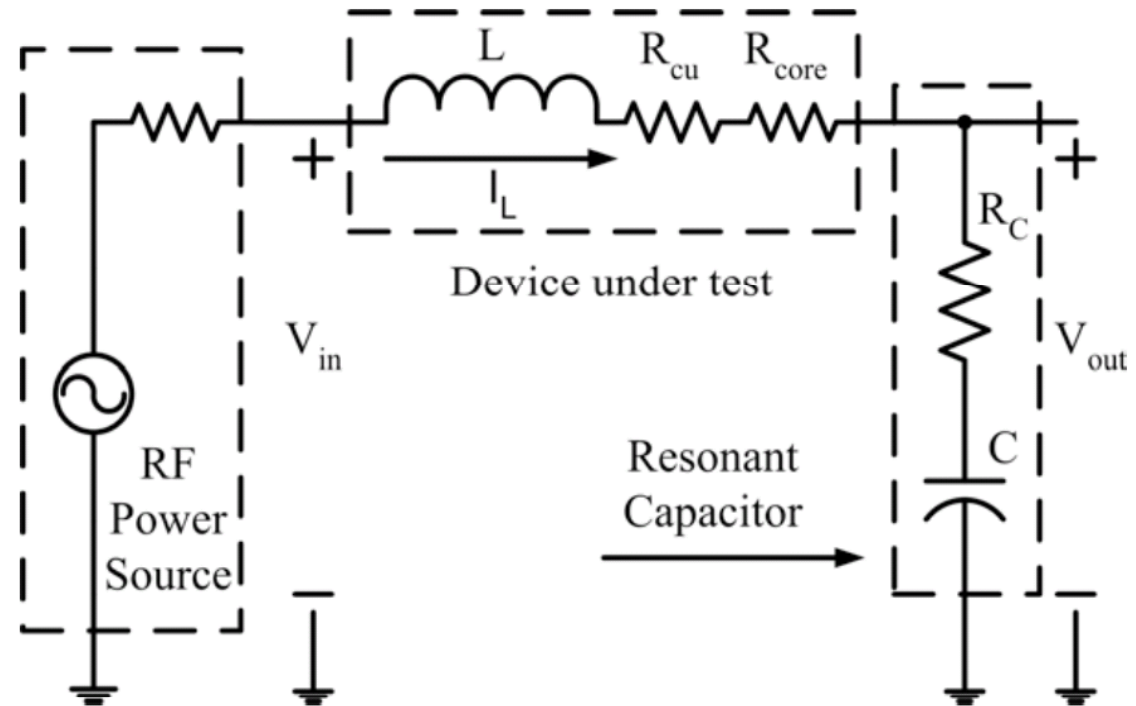

Test Fixtures

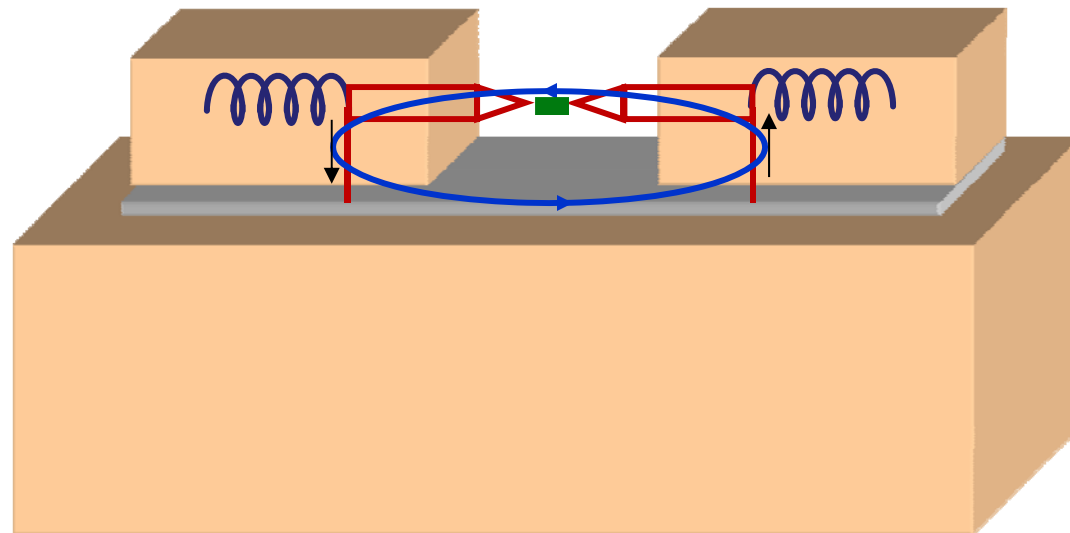

- Disadvantages of commercial fixtures
 - **Large stray** impedance (100 nH)
 - Most have **unrealistic test configuration**
 - Two point contacts have **large series resistance**



Low-stray surface-mount impedance-analyzer test fixture (Prabhakaran, 2002).

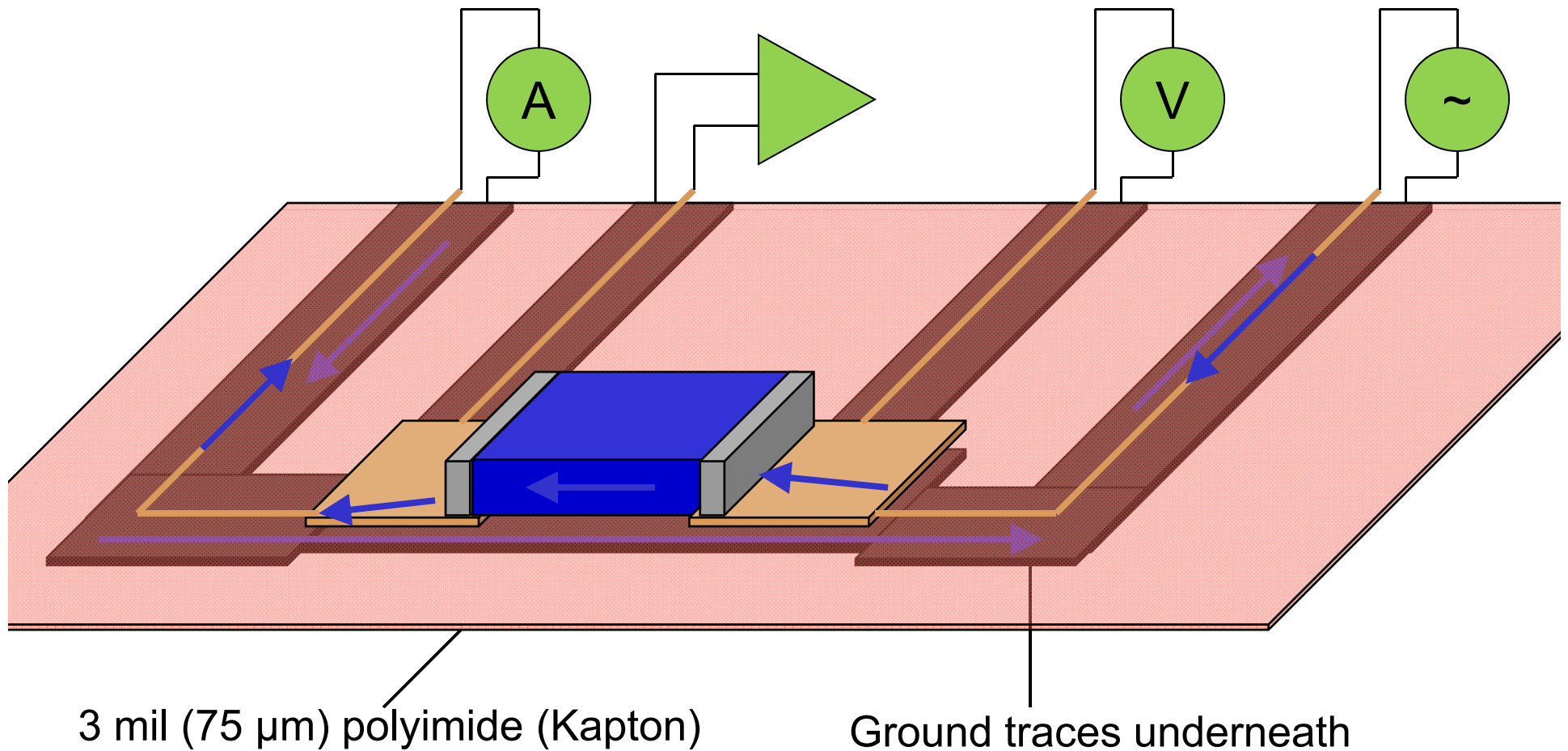
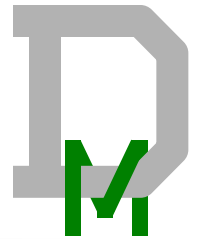

Test fixture performance at 10 MHz

(Prabhakaran, 2002).

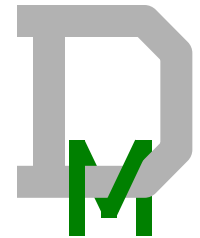

	Shorted		Open
	Stray L	Stray R	
Externally shorted	59 pH – 62 pH	1.35 m Ω - 1.38 m Ω	15 fF
Pre-shorted	43 pH	1.1 m Ω	



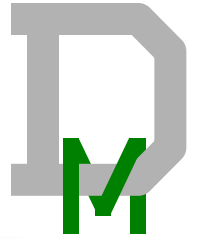

Separating core and winding loss

- Measure winding without core and subtract to get core loss?
- Measure core without winding and subtract?
- Core usually affects winding loss (gap, any asymmetry).
- To find winding resistance, measure small signal impedance and subtract small-signal core-loss effect.
 - Requires complex permeability data or measurement to describe the core.



Additional notes on winding measurement (added after presentation)

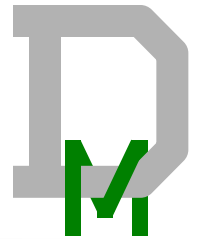

- For a two-winding transformer without much magnetizing current:
 - The most important resistance is for the excitation with no magnetizing current (“leakage excitation” or “transformer excitation”), obtained with equal and opposite amp-turns in the two windings.
 - This resistance can be measured with a shorted secondary (with high enough magnetizing inductance) or, for a 1:1 transformer, with windings connected in series opposition (Hayes 2009).
 - Core loss effects are typically negligible for ferrite cores with leakage excitation, so subtracting core loss is not necessary. (Not true for magnetizing excitation!)
- Stray capacitance leads to a parallel resonance at high frequencies in a typical component.
 - Find C value from resonant frequency.
 - Model including C leads to a difference between winding resistance and the ESR of the component. Using this model becomes important as frequencies approach the resonance.



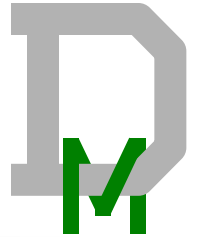

Typical procedure to measure ac resistance of an inductor winding (added after presentation)

- Calibrate analyzer with text fixture.
 - Consider using averaging over the same frequency range to be used in the impedance measurement.
- Measure $Z(f)$, typically using series inductance and series resistance as coordinates.
- Find resonant frequency (which may be outside the range initially scanned in the impedance measurement) and calculate capacitance.
- Measure impedance with closed gap (zero gap) to obtain small-signal core characteristic. If ESR measured in this configuration is much larger than ESR measured with a gap, the loss is mostly due to core loss. If not, see the next slide for alternatives to obtain core loss.
- The small-signal core loss characteristic can be used to calculate the component of the ESR attributable to the core loss. One way to do this is to use the fact that the parallel resistance due to core loss is constant independent of gap length.
- Winding resistance is obtained by subtracting core ESR and correcting for C.



Core loss measurements: small-signal and large-signal

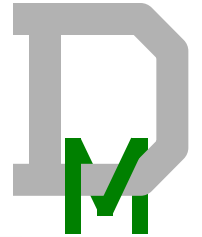

With a closed core (ideally with no gap):

- Classic two-winding measurement:
 - Small-signal or large-signal
 - Beware of capacitance to other winding or core, and of mutual resistance appearing as core loss.
 - Can use capacitor to make high-Q measurement more accurate (Mu, 2010) (important for low-perm cores)
- Subtract winding resistance (Valchev, 2005, Han 2008):
 - Known via modeling.
 - Litz wire in range where it's independent of frequency.
 - Measured...



Subtracting measured resistance for core loss...

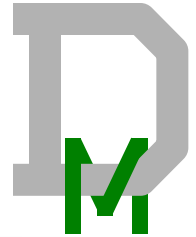

- Requirements:
 - Repeatable configuration.
 - Current distribution unaffected by core.
- Solution: coaxial connector (e.g. “7/16” high-power RF connector) with shorted mating connector.
 - Similar to commercial impedance analyzer “magnetic material test fixture”
 - May be better: full cylindrical symmetry vs. 4-post design.
 - Zero instrument with empty fixture; insert toroidal core.



Core loss measurements with thin-film samples

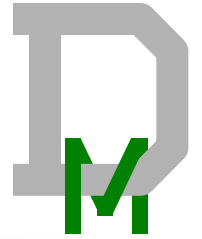

- Low-frequency high-field:
BH looper
(e.g., SHB Instruments)
- High-frequency low-field:
Permeameter
(e.g., Ryoawa)
- High-frequency high-field:
(Mukadam, 2008)

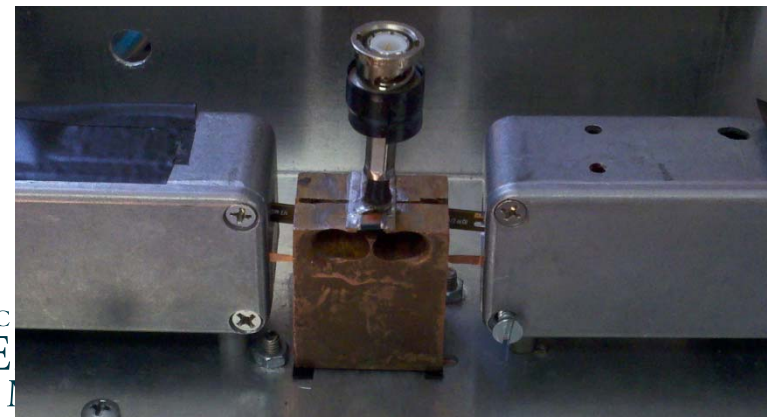
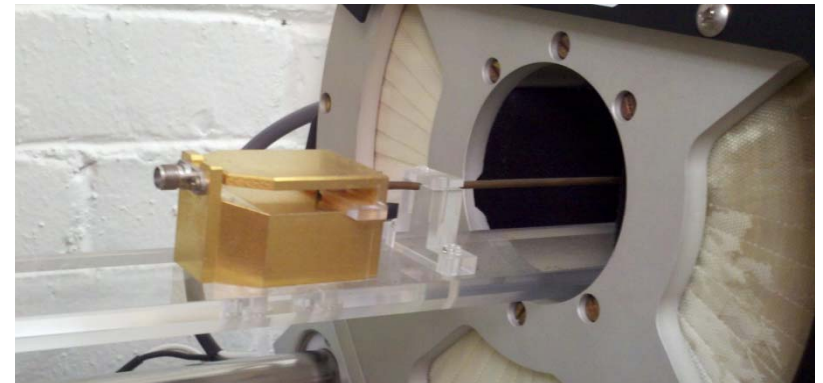
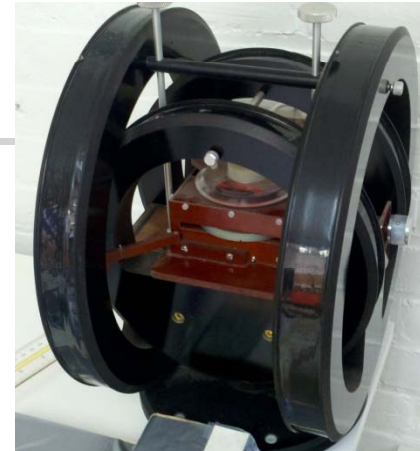

References



- Giorgio Bertotti, *Hysteresis in magnetism: for physicists, materials scientists, and engineers*, Academic Press, ISBN 978-0120932702, 1998.
- M.E. Dale and C.R. Sullivan, "Comparison of Single-Layer and Multi-Layer Windings with Physical Constraints or Strong Harmonics," *IEEE International Symposium on Industrial Electronics*, 2006. doi: 10.1109/ISIE.2006.295688
- Yehui Han, G. Cheung, An Li, C.R. Sullivan, D.J. Perreault, "Evaluation of magnetic materials for very high frequency power applications," *IEEE Power Electronics Specialists Conference (PESC)*, 2008. doi: 10.1109/PESC.2008.4592628
- J. G. Hayes, D. Cashman, M.G. Egan, T. O'Donnell, Ningning Wang, "Comparison of Test Methods for Characterization of High-Leakage Two-Winding Transformers," , *IEEE Transactions on Industry Applications* , vol.45, no.5, pp.1729-1741, 2009 doi: 10.1109/TIA.2009.2027549
- Jiankun Hu, C.R. Sullivan. "AC Resistance of Planar Power Inductors and the Quasidistributed Gap Technique." *IEEE Transactions on Power Electronics*, 16(4), July 2001, pp. 558 -567.
- Mingkai Mu, Qiang Li; D. Gilham, D.; F.C. Lee, K.D.T. Ngo, "New core loss measurement method for high frequency magnetic materials," *IEEE Energy Conversion Congress and Exposition (ECCE)*, 2010. doi: 10.1109/ECCE.2010.5618454
- J. Muhlethaler, J. Biela, J.W. Kolar, and A. Ecklebe, "Core losses under DC bias condition based on Steinmetz parameters," *International Power Electronics Conference (IPEC)*, 2010. doi: 10.1109/IPEC.2010.5542385
- J. Muhlethaler, J. Biela, J.W. Kolar, and A. Ecklebe,, "Improved core loss calculation for magnetic components employed in power electronic system," *IEEE Applied Power Electronics Conference and Exposition (APEC)*, 2011. doi: 10.1109/APEC.2011.5744829
- H. Mukadam, C.R. Sullivan and S. Prabhakaran, "A High-Field High-Frequency Permeance Meter for Thin-Film Materials," *IEEE Power Electronics Specialists' Conference*, 2008.
- Xi Nan and C. R. Sullivan, "Simplified High-Accuracy Calculation of Eddy-Current Losses in Round-Wire Windings." *IEEE Power Electronics Specialists Conference*, 2004.
- S. Prabhakaran and C.R. Sullivan, "Impedance-analyzer measurements of high-frequency power passives: techniques for high power and low impedance," *IEEE 37th IAS Annual Meeting*, 2002. doi: 10.1109/IAS.2002.1042734
- C. Schaef and C.R. Sullivan, "Inductor Design for Low Loss with Complex Waveforms," *IEEE Applied Power Electronics Conference*, 2012.
- J.H. Spreen, "Electrical terminal representation of conductor loss in transformers," *IEEE Transactions on Power Electronics*, vol.5, no.4, pp.424-429, Oct 1990. doi: 10.1109/63.60685
- C. R. Sullivan, "Aluminum Windings and Other Strategies for High-Frequency Magnetics Design in an Era of High Copper and Energy Costs", *IEEE Transactions on Power Electronics*, vol. 23, no. 4, pp. 2044–2051, 2008.
- Vencislav Cekov Valchev and Alex Van den Bossche, *Inductors and Transformers for Power Electronics*, 2005, CRC press, ISBN-13: 978-15744446791
- Di Yao and C.R. Sullivan, "Effect of Capacitance on Eddy-Current Loss in Multi-Layer Magnetic Films for MHz Magnetic Components," *IEEE Energy Conversion Conference and Exposition*, 2009.
- D. R. Zimmanck and C.R. Sullivan, "Efficient Calculation of Winding Loss Resistance Matrices for Magnetic Components," *IEEE Workshop on Control and Modeling for Power Electronics (COMPEL)*, 2010.